



*heating and plumbing products  
that won't cost the **earth***

**Low pressure  
thermostatic mixing valve**

July 2010



# Low pressure solar thermostatic mixing valve

This valve prevents very high temperature water from entering the DHWS taps and outlets.

NOTE: This valve can be used in conjunction with TMV2 and TMV3 - but not instead of.

### Technical specification

Temperature stability	± 2°C
Inlet temperature range	55 - 65°C Hot supply ≤25°C Cold supply
BS EN1287 working pressure range	0.1-1.0 Low pressure
Min temperature differential mix to hot for fail-safe	10°C
Max pressure inlet differential	5:1
Max inlet operating temperature	110°C

1 It is essential before installing any of the series 60007 thermostatic mixing valves, that you ensure that the supply conditions of the system to which the valve is intended to be fitted are checked to confirm compliance with the parameters as quoted within the technical specifications and conditions on which the approval is granted - i.e. verify supply temperatures, supply pressures and risk assessment.

2 The supply system to which the series 60007 thermostatic mixing valve is to be installed, must be thoroughly flushed and cleaned to remove any debris which may have accumulated during installation. Failure to remove any debris will affect the performance and the manufacturer's warranty of the product. Independent filters/check valves and isolation valves must be fitted in conjunction with the valve. In areas that are subject to aggressive water, provision must be made to treat the supplies prior to the supplies entering any Intaeco product.

3 The maximum flow rate of the valve will only be achieved when the supply conditions are achieved as quoted within the technical specification, with flow conditions under 1 bar differential pressure.

4 The Intaeco low pressure thermostatic mixing valve has been designed to be installed in any position whether vertical or horizontal. It can be surface mounted or within a supply duct. But it is essential that access to the valve is not obstructed to allow for any future maintenance that may be required to the valve or associated fittings.

5 The hot and cold water supplies must be connected to the valve strictly in accordance with the indications on the body of the valve i.e. hot water supply to the hot water port of the valve.

6 In a situation where one or both of the water supplies are excessive, it is possible to fit a pressure reducing valve to reduce the pressure(s) to within the limits quoted previously.



Low pressure solar thermostatic mixing valve

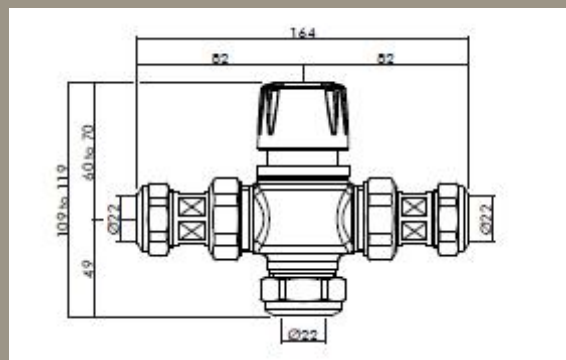

### Flow rate

Mixed water @ 46°C						
Pressure (bar)	0.2	0.3	0.5	1.0	1.5	2.0
Litres/minute	15	18	22	30	36	42

### Typical installation

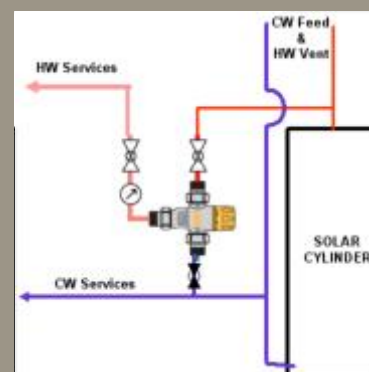

## Low pressure solar thermostatic mixing valve

Full bore isolation valves and Y pattern strainers can be used in conjunction with the low pressure solar thermostatic mixing valve, but on gravity systems the open vent must NOT be obstructed in any way or at any time.

Before commissioning, the system should be thoroughly cleaned and flushed of any debris. Note, it is possible that if the flushing of the system with a chemical not in accordance with the requirements of BS 6700. HSE documents L8 and HTM 2040 may partially remove the lubricant from the internal workings of the valve. We recommend that the valves performance be checked after flushing.

If a water supply is fed by gravity, then the supply pressure should be verified to ensure that the conditions of use are appropriate for the valve. The installation of thermostatic mixing valves must comply with the requirements of the Water Supply (Water Fittings) regulations 1999.